

# **Feasibility study for installing photovoltaic power plant on “Krajevna skupnost Bertoki” building in Koper**

D.III.1

May, 2022

Prepared by: Energy Institute Hrvoje Požar

# Table of Contents

<b>1</b>	<b>Development and use of photovoltaic systems .....</b>	<b>6</b>
<b>2</b>	<b>Basic elements of PV system .....</b>	<b>8</b>
2.1	Photovoltaic modules .....	8
2.2	Inverters .....	9
2.3	Prefabricated construction .....	9
2.4	Other electrical equipment (AC and DC cables, cabinets etc.) .....	12
2.5	Grid connection .....	12
<b>3</b>	<b>Location and object description .....</b>	<b>13</b>
<b>4</b>	<b>Conceptual design of a solar power plant .....</b>	<b>14</b>
4.1	Selection and dimensioning of basic elements .....	14
4.1.1	Photovoltaic modules .....	15
4.1.2	Inverter .....	15
4.1.3	Mounting structure for modules .....	16
4.2	Elements layout on the roof .....	16
4.3	Electric system configuration .....	18
<b>5</b>	<b>Estimation of electricity production .....</b>	<b>19</b>
5.1	Methodology and estimations of electricity production on site .....	19
5.1.1	Solar radiation on site .....	20
5.1.2	Location shading .....	22
5.2	Electricity production estimation .....	22
5.3	Possibility analysis of electricity consumption at the location .....	23
<b>6</b>	<b>Basic parameters .....</b>	<b>25</b>
6.1	Estimation of Investment .....	25
6.2	Estimation of Operational costs .....	26
6.3	Model for estimation of self-consumed electricity in energy community .....	26
<b>7</b>	<b>Financial analysis .....</b>	<b>26</b>
<b>8</b>	<b>Conclusion .....</b>	<b>28</b>

**Tables**

Table 4-1 Basic technical characteristics of selected photovoltaic module .....	15
Table 4-2 Basic electric characteristics of inverter .....	15
Table 4-3 Basic data on technical solution .....	17
Table 5-1 Basic data from the meteorological stations in the vicinity of the location and Koper .....	20
Table 5-2 Average daily irradiances of the horizontal surface and the mean air temperatures by months .....	21
Table 5-3 Parameters for electricity production estimation .....	22
Table 5-4 Electricity production results based on proposed technical solution .....	23
Table 6-1 Estimated investment costs, by category .....	25
Table 7-1 Financial indicators of cost-effectiveness for the project .....	27
Table 7-2 Sensitivity analysis – Variability of investment in PV system and increase of high tariff electricity supply .....	27

**Figures**

Figure 1-1 Solar cell, photovoltaic module, and photovoltaic field .....	7
Figure 1-2 An example of a PV system integrated into a building and a PV system on flat roof .....	7
Figure 2-1 Common PV module technologies .....	8
Figure 2-2 Examples of string inverters (left) and centralized high-power inverters (right) .....	9
Figure 2-3 Example of mounting structure for slope roof .....	10
Figure 2-4 Example of mounting structure for flat roof .....	10
Figure 2-5 Example of determining the minimum spacing between module rows .....	11
Figure 2-6 Example of integrated photovoltaic 29.64 kW power plant realization .....	11
Figure 3-1 Zadružni dom Bertoki building .....	13
Figure 3-2 Photo of southwest facade .....	14
Figure 4-1 Sketch of the substructure installation on the roof .....	16
Figure 4-2 Elements layout on the roof of KS Bertoki power plant (southwest part of the roof, southeast part of the roof, south part of the roof) .....	17
Figure 4-3 Single-pole circuit diagram of the PV modules and the exchangers .....	18
Figure 5-1 Average daily irradiances of the horizontal surface and the mean air temperatures .....	21
Figure 5-2 Shading on site, polar diagram display .....	22
Figure 5-3 Monthly consumption in relation to PV production for KS Bertoki .....	24
Figure 5-4 Energy flow graph (kWh) .....	24

## **Abbreviations**

AC	Alternating current
BIPV	Building integrated photovoltaics
CAPEX	Capital expenses
DC	Direct current
DSO	Distribution system operator
EIHP	Energetski institut Hrvoje Požar
GCA	Grid connection authorisation
IRR	Internal rate of return
KS	Krajevna skupnost
NPV	Net present value
OPEX	Operation expenses
PBP	Payback period

---

## **Introduction**

The SOLAR ADRIA project within the European Climate Initiative (EUKI), financed by the Federal Ministry for the Environment, Nature Conservation and Nuclear Safety of the Federal Republic of Germany aims to accelerate solar power development in the coastal Adriatic municipalities. The objectives of the project are to explore on a municipal level how stakeholders perceive and contribute to energy transition through solar development, to provide solar potential maps for target municipalities and create a matchmaking platform to connect any interested investors with the municipality administration and other stakeholders. One goal is to help develop two solar projects, one in each pilot municipality, by providing technical and economic information on potential projects. In that sense, feasibility studies for selected projects were performed.

The feasibility study serves for technical and economic evaluation of the selected roof and associated building (in this case consume). Before the realisation of the feasibility study, meetings with local policy makers were held. At the meeting in December 2021 with representatives of Koper municipality, the two roofs for feasibility studies were selected:

1. Roof of "ŠD Burja" building
2. Roof of "Zadružni dom Bertoki" building

These two buildings are in the ownership of the Municipality of Koper. The baseline documentation has been delivered and based on this information the studies were performed. The result of the study will serve to the building owner (Municipality) to make a better informed decision on next steps and the final decision on whether to invest in the PV project. In case of a positive decision, the next step is full project documentation development for one of the projects, that will be also done through Solar Adria project.

# Basic info on solar photovoltaic (PV) systems

## 1 Development and use of photovoltaic systems

Historically, the first wider application of PV modules was to supply power to satellites in Earth orbit. Another historically important application is autonomous power supply systems for remote buildings, such as lighthouses. Today there is a wide array of applications. Application of PV for production of renewable electricity is expected to increase in the future and that the interest in PV installations will grow rapidly.

Photovoltaic systems convert solar radiation from the Sun into electricity based on photovoltaic effect, ie the generation of an electric charge carrier in a semiconductor material during illumination.

Based on their purpose, photovoltaic systems can be divided on:

- Autonomous photovoltaic systems, used to supply electricity to facilities that are not connected to the electricity grid (e.g. lighthouses, mobile telephony base stations etc.),
- Grid-connected photovoltaic systems, used to produce and transmit the electricity to the network.

The later ones can be divided according to the location of installation into:

- Photovoltaic power plants on buildings - photovoltaic modules are installed on the outer shell of buildings, most often on sloping or flat roofs of buildings. In recent times, we can see the increasing use of so-called BIPV (Building integrated photovoltaics), where photovoltaic modules are used as elements of the building envelope.
- Photovoltaic power plants on the ground - centralized plants for the production of electricity, divided according to the method of installation of photovoltaic modules into:
  - power plants with fixed mounted modules and
  - power plants with Sun tracking modules.

The basic functional element of photovoltaic systems is a solar cell, a semiconductor element similar to a diode, with an area of several  $\text{cm}^2$ , which when illuminated gives a maximum output voltage of 0.5 – 0.7 V and an output current of about 1 A. The efficiency of a solar cell depends on manufacturing technology.

As one solar cell has a relatively small output power, solar cells are electrically and mechanically connected to a photovoltaic module to achieve higher power. A photovoltaic module is a ready-

made device that can generate electricity, but as they are produced at relatively low power (up to a maximum of several hundred watts), more photovoltaic modules are stacked in a photovoltaic field to achieve higher power.



*Figure 1-1 Solar cell, photovoltaic module, and photovoltaic field*

As previously mentioned, photovoltaic systems can be installed on residential, commercial or industrial buildings, either on roofs or as an element of the facade. In the case of tilted roof, photovoltaic modules are mostly placed to follow the slope and orientation of the roof, which in most cases will not coincide with the optimal placement of the photovoltaic module. In the case of placing photovoltaic modules on a flat roof, it is possible to place the system at an optimal angle, facing south. Placing photovoltaic modules on the roofs of buildings does not take up additional space, and energy is in most cases used at the site of conversion. Most of the photovoltaic systems on the roofs of buildings have installed capacity up to 100 kW. Larger installations are also possible, but not very common.

The main advantages of using photovoltaic systems as the energy system of a building are the production of electricity at the point of consumption, modularity and flexibility.



*Figure 1-2 An example of a PV system integrated into a building and a PV system on flat roof*

The daily electricity consumption profile usually coincides well with the profile of electricity generation from the photovoltaic system, so it is to be expected that most of electricity produced

will be used on site. Such an approach will result in a reduction in electricity taken from the grid, a partial reduction in the power involved and a direct increase in the share of renewable energy sources.

The use of energy storage (battery storage banks) is common in autonomous photovoltaic systems and is rarely used in grid-connected photovoltaic power plants.

## 2 Basic elements of PV system

Basic elements of photovoltaic power plants are:

- Photovoltaic modules
- Inverters
- Prefabricated construction
- Other electrical equipment (AC and DC cables, cabinets etc.)
- Grid connection.

### 2.1 Photovoltaic modules

Solar cells can be produced from a lot of different semiconductor materials. Most commonly used material is crystalline silicon which can be in form of monocrystalline silicon or polycrystalline silicon. Photovoltaic modules made from crystalline silicon are first generation modules with high efficiency in transforming solar radiation into electricity (from 13 to 21% per one module) and good temperature and time stability. Second generation of photovoltaic modules are thin-film modules made from amorphous silicon, cadmium telluride, copper-indium-gallium sulfide, microcrystalline silicon and other similar materials. These modules have some lower production price but also lower efficiency which means that they need larger surface area to place same installed power as the first-generation modules. Some of materials used for second generation modules have high temperature instability and marked aging immediately after installing. The third generation of photovoltaic modules includes various photovoltaic coating solutions, organic solar cells and specially designed cells for the use of concentrated solar radiation (solar towers). First and second generation of photovoltaic modules are commercially available on the market while third generation modules are still in the experimental phase, in certain pilot plants.

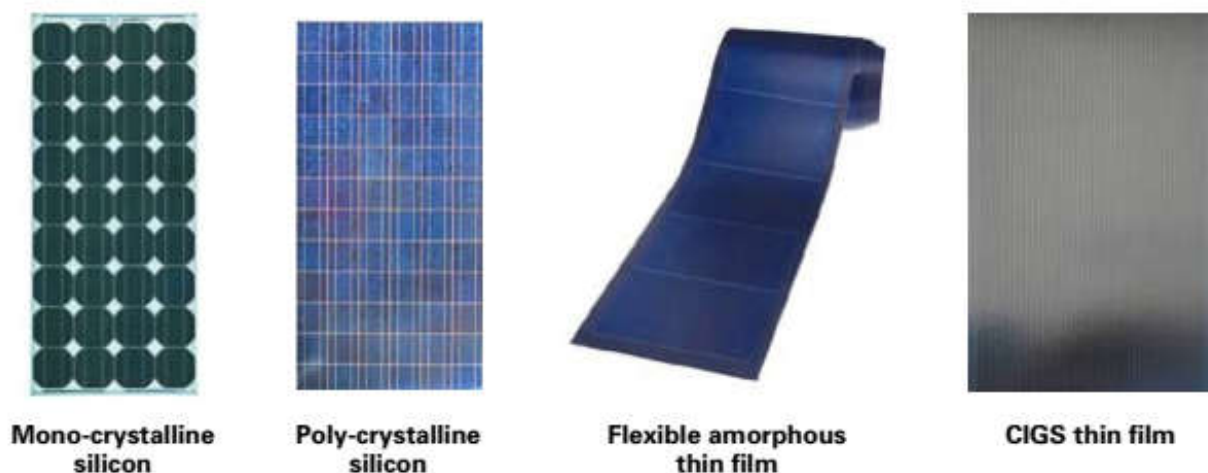

Figure 2-1 Common PV module technologies (Source: EMA & BCA)



Time degradation in photovoltaic modules can have significant impact on the reduction of production. The usual degradation for crystalline modules is 1-3% for the first year, followed by a linear decline of about 0,5-0,8% annually. By mid-life the rated power of the module is 90% of the initial power and after 25 years of usage is about 80% of rated power. For thin film technology, degradation has not yet been sufficiently proven in practice.

Photovoltaic modules generate direct electric current and come in relatively low power (up to several hundred watts). In order to obtain the desired voltage of the DC part of the internal electrical network, the photovoltaic modules are connected in strings by serial connections. By connecting several strings in parallel, the desired power of the PV field is obtained, which is connected to the inputs of the inverter.

The choice of the modules themselves will depend on the available space, price, relative humidity etc. The criteria for choosing the module are its efficiency, power tolerance, temperature coefficient and resistance to high humidity conditions.

## 2.2 Inverters

Inverters convert direct voltage and electric current into alternating voltage and electric current of a certain frequency suitable for transmission to the electric power grid. In addition to converting voltage, they have the functions of monitoring the operating point of the PV generator and setting it to the point of maximum power, protection, and disconnection of the system in case of system or network failure, and additional functions of monitoring system operation, fault detection, system malfunction signalling etc. Not all functions need to be integrated in one device. Inverters are available on the market in a wide range of manufacturers, power and output voltages, and their configuration is selected depending on the needs and technical feasibility of each system. Depending on the size of the power plant and configuration of the building the designer can decide on size of inverters used and place of installing.



Figure 2-2 Examples of string inverters (left) and centralized high-power inverters (right)

Both types of inverters can be used, depending on the size of the power plant. All technical issues such as specific location of inverters, adjustments and other special features should be considered in relation to the specific site, this is proposed by the designer of power plant.

## 2.3 Prefabricated construction

Photovoltaic mounting systems are used to fix solar panels on roof surfaces or building facades. In terms of sloped roofs, the photovoltaic modules are generally mounted with a few centimetres gap and parallel to the surface of the roof. Railed mounting system is most common used for

sloped roofs. It consists of set of rails attached to the rooftop and solar panels attached to the rails with a set of clamps. The rails are secured to the rooftop by screws and bolts. Another type is rail-less mounting system which uses bolts and screws to secure each panel directly to the roof. Advantages of this solution are lower manufacturing and shipping costs but requires experienced installers. It is advisable not to use this mounting system on tile roofs. Shared rail mounting system is like the railed system with difference in number of rails needed to be installed. This system uses three rails for two solar panels row instead of four by using two rails on the edges and one in the middle that shares the two rows.



Figure 2-3 Example of mounting structure for slope roof (Source: <https://en.irfts.com/>)



Figure 2-4 Example of mounting structure for flat roof (Source: <https://www.pv-magazine.com/>)

In the case of horizontal rooftop the main mounting system used is known as the flat roof ballasted racking system. Advantages of this mounting system are fast and easy installation and no need for perforations in the roof. It consists of a pre-assembled structures with panels attached using clamps and clips. A set of ballasted blocks go to the bottom of the structure and act as the support for the system. It is relatively easy to retrofit panels directly on top of existing roofing structures using mounting systems.

Photovoltaic modules on flat roofs are placed tilted under a certain angle on the load-bearing structure in a regular rectangular arrangement. The rows of photovoltaic modules are placed one behind the other, with a distance between them planned to avoid shading in the worst case

(winter solstice) from the row in front, which reduces surface efficiency compared to sloping roofs.

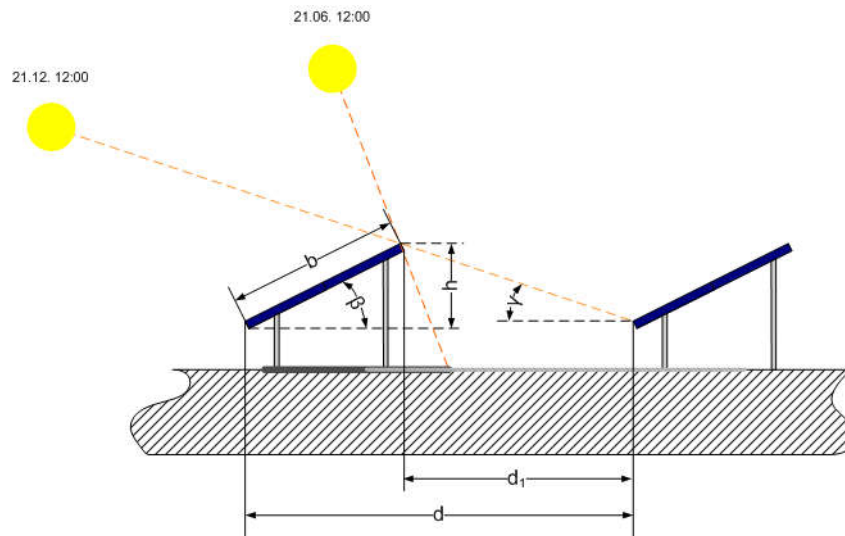

Figure 2-5 Example of determining the minimum spacing between module rows

Typical surface occupancy, assuming the use of photovoltaic modules in crystalline silicon technology, for sloping roofs is about 150 W/m<sup>2</sup>, while for the use of systems on flat roof surfaces it is about 60 to 70 W / m<sup>2</sup>.



Figure 2-6 Example of integrated photovoltaic 29.64 kW power plant realization (source: HEP)

The load-bearing substructure on which the PV modules are placed is usually made of aluminum and, depending on the type of roof, is attached to the roof structure or an additional load is placed on the load-bearing structure for flat roofs for stability.

As a rule, integrated solar power plants use a larger number of lower power exchangers (up to several tens of kilowatts). However, the approach to choosing the concept of using the inverter is solely up to the system designer.

If the panels are planned to be mounted before the construction of the roof, the roof can be designed accordingly by installing support brackets for the panels before the materials for the roof are installed.

In all cases of retrofits, a particular consideration for weather sealing is necessary. This is ensured by the use of equipment from reputable manufacturers and installation by certified installers. The user on whose roof the power plant is installed does not need to take additional activities to ensure that its roof will not leak.

#### 2.4 Other electrical equipment (AC and DC cables, cabinets etc.)

Other electrical equipment is standard electrical equipment which is installed in any other electrical installation, whether a house or an industrial plant.

#### 2.5 Grid connection

Grid connection procedure starts by applying for GCA (Grid Connection Authorisation) for DSO (distribution system operator). DSO requires to have an initial or preliminary design so that it can analyse nearby grid and estimate grid connection costs.

GCA defines the agreed power, voltage level, location, technical terms and conditions, planned energy production, estimation of grid connection costs and costs of improving nearby grid (if necessary to enable energy flow from grid connection point to wider grid), assumed date of connection etc.

DSO is in charge of all grid connection works which are defined in Grid Connection Authorisation.

# Technical analysis of the proposed object

The object of interest for installation of PV power plant is "Zadružni dom Bertoki" located in the municipality of Koper. All electricity produced in the photovoltaic power plant would be used to meet the facility's own electricity needs.

## 3 Location and object description

Zadružni dom Bertoki is an existing building located in the municipality of Koper, Slovenia, on the Adriatic coast. The building consists of ground floor, first floor and sloped roof shaped in form of letter "L". The building extends in the direction northeast-southwest in length of approximately 43 m and northwest-southeast in the length of approximately 40 m. The roof is sloping on four eaves with different surfaces and different slopes and it is covered with roof tiles, with a ridge height of approximately 10.5 m.

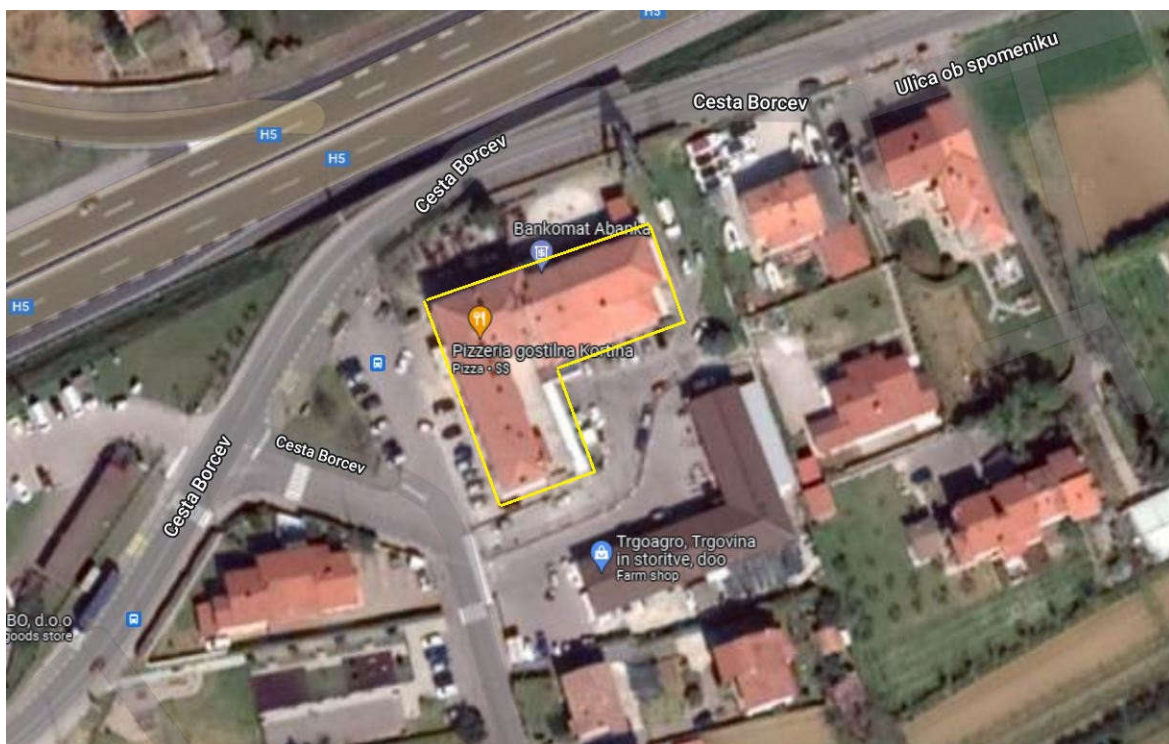

Figure 3-1 Zadružni dom Bertoki building



Figure 3-2 Photo of southwest facade

## 4 Conceptual design of a solar power plant

### 4.1 Selection and dimensioning of basic elements

The choice of specific equipment for the construction of a solar photovoltaic power plant depends on several factors. The most important factors are the price of the equipment itself and the expected production of electricity, but other factors in some cases decisively influence the choice, such as the suitability of the technical solution, market availability, reliability and experience of equipment manufacturers and suppliers and the like. Considering the relatively large number of PV manufacturers (about 600), available models of PV modules, the constant advancement of technology, as well as the relatively large number of manufacturers of inverters, the conceptual design can provide only one of the possible final solutions.

Most manufacturers offer monocrystalline PV modules that are currently the most cost-effective solution. In the early phase of the project, it is important to outline a possible technical solution, electricity production and the size of investment. Ultimately, the proposed solution in this document will almost certainly differ from the final solution, whether in the choice of specific PV modules, inverters, electrical and construction configuration of the element etc.

Therefore, the possible performances of the power plant were based on certain type of selected equipment and should not be considered the final choice for the realization of the power plant, nor the definition of the necessary technical characteristics. The final choice of a specific solution will depend on factors such as price, availability and expected electricity production, and cost-effectiveness of a particular solution defined by the specific price.

The experience shows that prices for similar configurations of different manufacturers and / or equipment suppliers can vary by up to 20%. The concrete selection of equipment for the construction of the power plant takes place in the later stages of the project, shortly before the start of construction of the power plant.

#### 4.1.1 Photovoltaic modules

Photovoltaic modules are briefly described in the first chapter of the study. Among the analysed modules, high-efficiency polycrystalline modules, type SV72-330 manufactured by Solvis, were selected for the development of conceptual solutions. The selected modules do not represent the best or latest module technology available on the market, but well-tested technology that has been in use for a long time. With this choice, the intention is to be on the safety side when assessing the possibility of installed power on the roof of the building. If there is enough space on the roof to achieve the required power of the power plant with older generation modules then the assumption is that the given power can certainly be achieved with more efficient newer generation modules.

Table 4-1 Basic technical characteristics of selected photovoltaic module

<b>Solvis SV72-330</b>			
Maximum power	P <sub>max</sub>	330	W
Module efficiency	$\eta$	17.01	%
Maximum Power Voltage	U <sub>mpp</sub>	38.86	V
Maximum Power Current	I <sub>mpp</sub>	8.50	A
Open-circuit Voltage	U <sub>oc</sub>	46.08	V
Short-circuit Current	I <sub>sc</sub>	8.87	A
Temperature Coefficients of P <sub>max</sub>	$\gamma$	-0.41	%/K
Dimensions	L x W	1956 x 992	mm x mm
Weight		22.5	kg

#### 4.1.2 Inverter

When developing the conceptual design, it was assumed to use the Huawei Technologies string inverters, SUN2000-17KTL-M0 with a nominal power of 17 kW and two SUN2000-10KTL-M0 string inverter with a nominal power of 10 kW.

Table 4-2 Basic electric characteristics of inverter

	<b>SUN2000-17KTL</b>	<b>SUN2000-10KTL</b>
Recommended max. PV power [kWp]:	26.88	14.88
Max. input voltage [V]	600	600
Max. apparent power [kVA]:	17.00	10.00
European weighted efficiency:	97.8 %	97.8 %

#### 4.1.3 Mounting structure for modules

Photovoltaic modules need to be mounted on a typical prefabricated substructure for sloping tiled roofs. The structure elements (rails) on which the photovoltaic modules will be mounted must be fixed directly to the roof of the building. Fastening of photovoltaic modules to rails must be performed with special clamps for fastening photovoltaic modules.

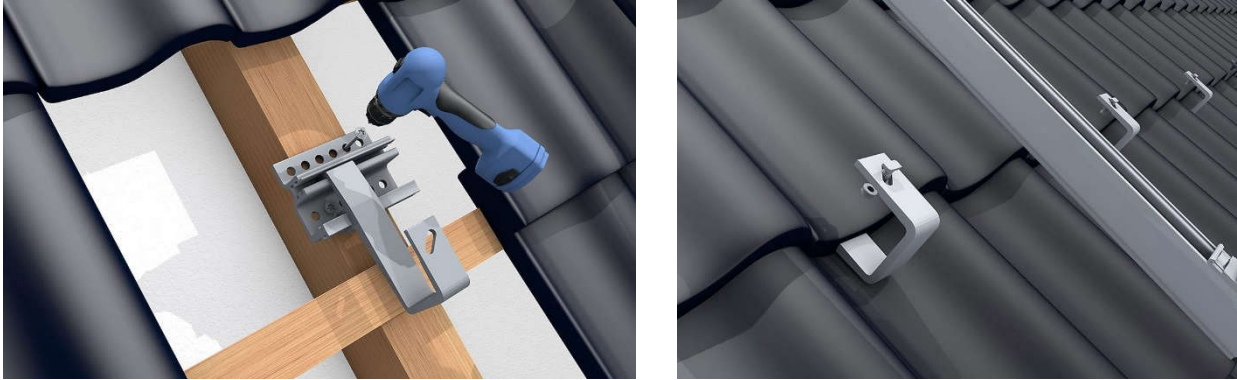

Figure 4-1 Sketch of the substructure installation on the roof (Source: <https://www.tritec-energy.com/en/>)

#### 4.2 Elements layout on the roof

According to the proposed technical solution for solar power plant elements layout, consumption of the facility and period of return on investment, it is possible to realize a solar power plant with installed PV field power of about 42,9 kWp and installed AC power of 37 kW.

The proposed arrangement of the elements on the roof of Zadružni dom Bertoki is shown on Figure 4-2. Photovoltaic elements are placed on the roof in such arrangement to maximize roof usage considering chimney positions and their shadow.



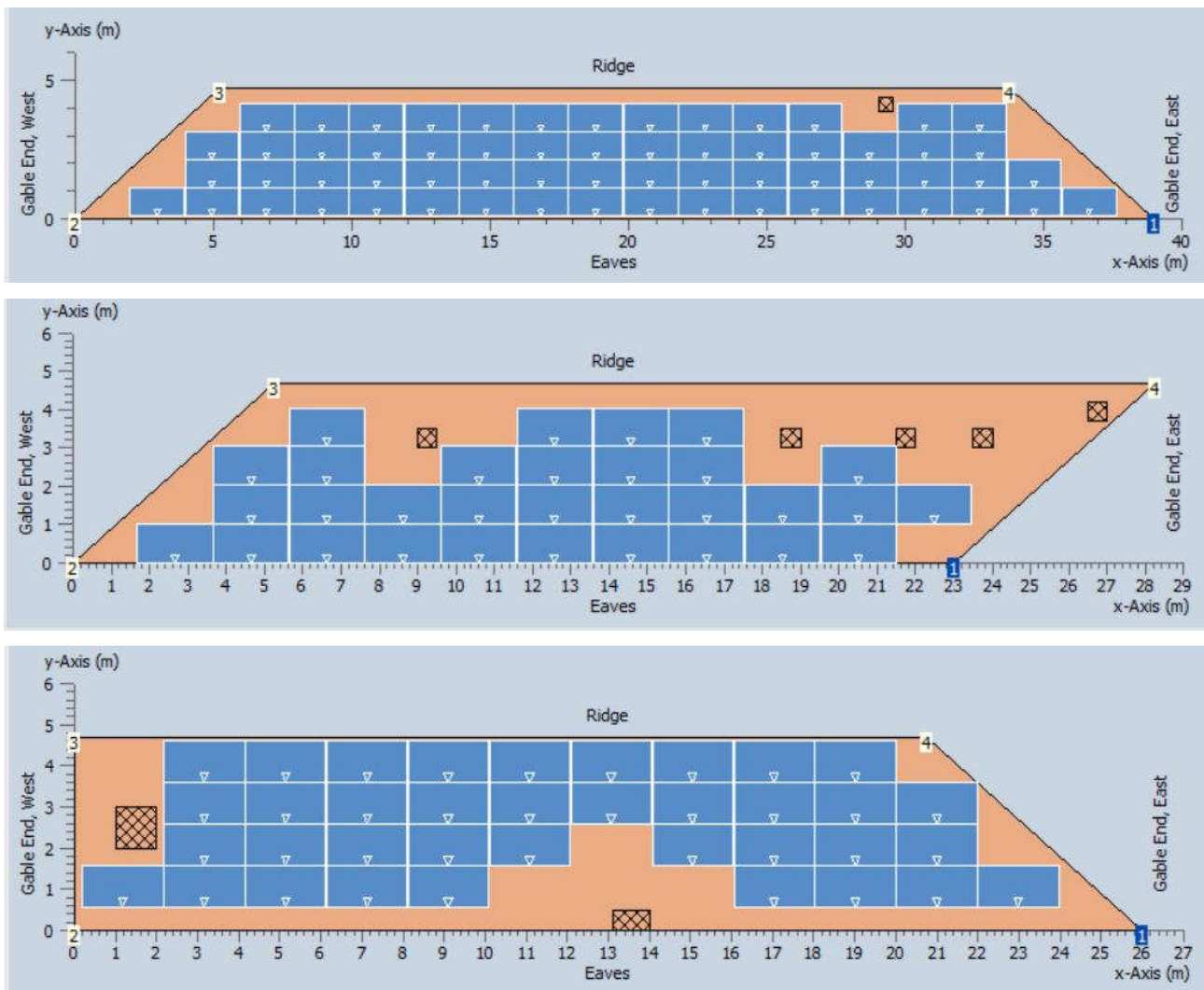

Figure 4-2 Elements layout on the roof of KS Bertoki power plant (southwest part of the roof, southeast part of the roof, south part of the roof)

To achieve the calculated power, it is necessary to install 130 photovoltaic modules, which are placed in 4 rows horizontally for the purposes of this study. Since the modules have dimensions of 1.956 x 0.992, the total area occupied by the modules on the roof is 252.25 m<sup>2</sup>.

Table 4-3 Basic data on technical solution

	Technical solution
PV module power [W]	330
Number of PV modules	130
Total PV power [kW <sub>p</sub> ]	42.9
Max. apparent inverter power [kVA]	37
Number of inverters	3
Total inverter power [kW]	37

4.3 Electric system configuration

Technical solution of this photovoltaic power plant is made of one 17 kW power inverter and two 10 kW power inverters that are connected to a PV field via eight strings. First, 17 kW power inverter is connected to two strings consists of 16 PV modules each and two strings consists of 15 PV modules each, with total power of 20.46 kWp. Second, 10 kW power inverter is connected to two strings consists of 19 PV modules and 18 PV modules, with total power of 12.21 kWp. Third, 10 kW power inverter is connected to two strings consists of 16 PV modules and 15 PV modules, with total power of 10.23 kW. That makes total PV field power of 42.9 kWp. Figure 4-3 shows a single-pole circuit diagram of the PV module and the exchanger according to the technical solution.

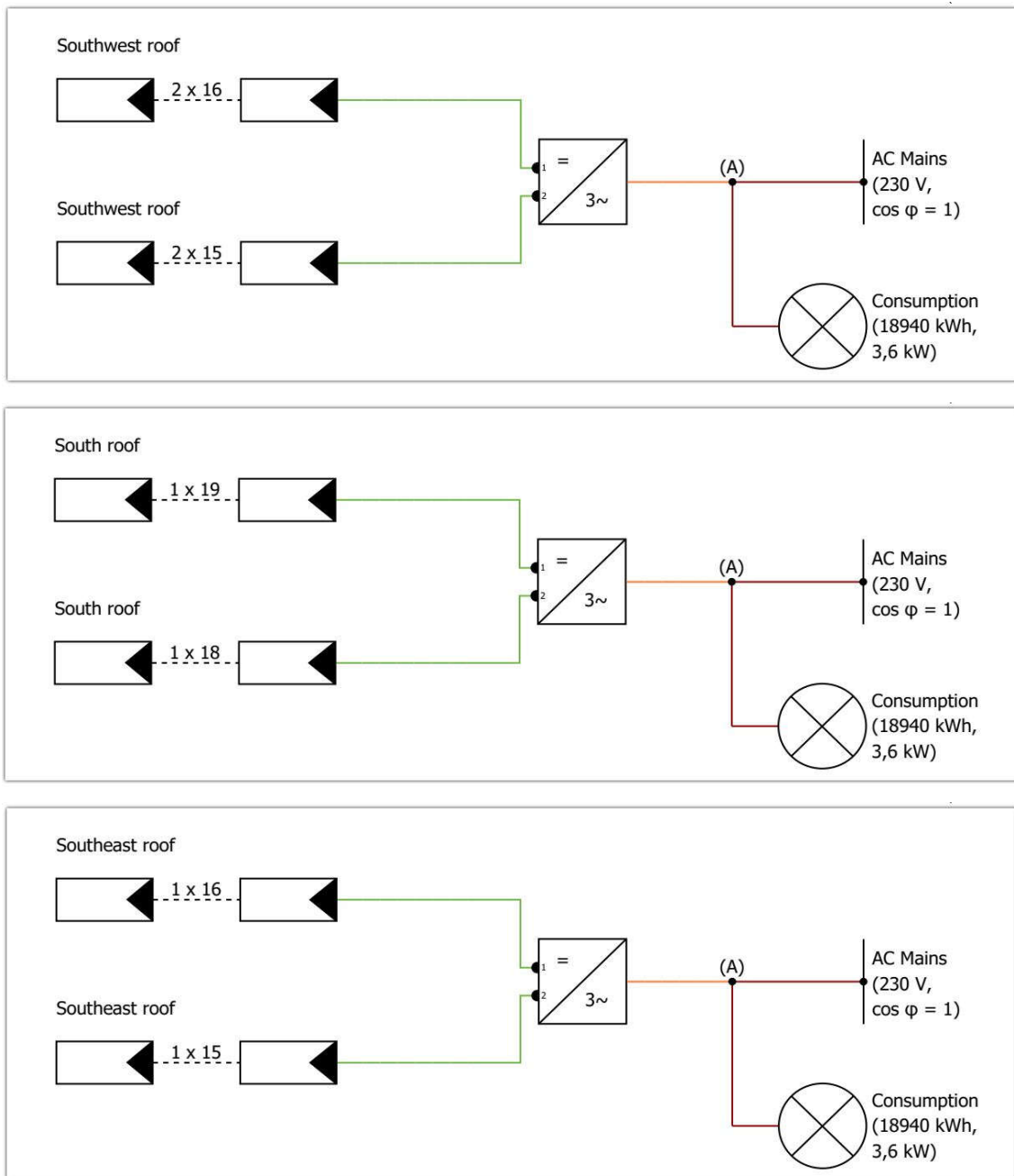

Figure 4-3 Single-pole circuit diagram of the PV modules and the exchanger1, exchanger2 and exchanger3

The output voltage level of the inverter is 0.23 kV, so the power plant can be connected directly to the customer's installations without the need to convert the voltage level.

## 5 Estimation of electricity production

### 5.1 Methodology and estimations of electricity production on site

The basic parameter that describes the solar radiation potential of a certain location is solar radiation on a horizontal surface, while the radiated energy on a sloping surface is more important parameter for the energy use of solar radiation. The estimation of the energy potential of solar radiation should be based on long-term measurements of solar radiation and application of well recognized methods. Data on solar radiation are available in various publications, databases, and publicly available online tools. These data are mostly obtained by measurement, satellite tracking or estimation. Some of the data sources are explained below.

**Meteonorm database** on solar radiation was published by the Swiss company Meteotest. This database contains labelling data based on measurements from over 8,000 meteorological stations, five geostationary satellites, and globally calibrated aerosol climatology. Based on this, sophisticated interpolation models provide results with high accuracy worldwide. In addition to average data, multi-year data sets are also available. Furthermore, a site-specific data interpolation tool is available, based on available data from sites for which the data is available.

**PVGIS (Photovoltaic Geographical Information System)** is a publicly available tool for estimating the value of solar radiation and the productivity of the photovoltaic system for Europe, Africa and Southwest Asia. The tool is based on international databases and provides open data and software architecture and high-resolution climate and geographic data integrated into a geographic information system (GIS). The user interface is based on the application of maps and is also available to non-experts in the application of solar energy. Algorithms for modelling radiometric data as well as climatological data are based on the European Atlas of Solar Radiation. Due to its wide spatial scope, this tool does not cover some locally specific elements, and it is justified to use it in the absence of sufficiently reliable local data. Shading (calculated in PVGIS) covers obstacles on the horizon visible from the position of the photovoltaic system, and are global, caused by further objects such as hills. Shading assessment involves determining the height and orientation of recognized objects on the horizon. The list of shadows, with the exact azimuth and height of each obstacle is the result of the shadow assessment, and can be graphically displayed in a polar diagram of the apparent motion of the Sun.

The calculation of electricity production from a photovoltaic power plant is based on the simulation of the behaviour of the selected photovoltaic system in a simulation computer tool specializing in sizing, calculation of production and cost-effectiveness of photovoltaic systems, based on average climatological data. The computer tool contain a database of photovoltaic system components (photovoltaic modules and inverters), with the characteristics of individual components, in order to properly simulate the operation of the system. The **PV \* Sol 2022 tool** was used in this study.

In addition to the estimation of electricity production, the output from the simulation can include a whole range of various climatological and technical data, such as the radiation values of the surface of photovoltaic modules, module temperature, exchanger efficiency, overall system efficiency, etc. Furthermore, in the long-term assessment of electricity production during the life of the power plant, it is necessary to take into account the aging (degradation) of PV modules,

which is manifested by a decrease in rated power of PV modules, and consequently a decline in electricity production. The typical value for PV modules is about 0.55% per year.

The calculation of electricity production was done in good faith, with average climatological data. However, this calculation should not be taken as a guarantee of production, since in a given year, radiated energy can vary up to 30% compared to the average values, and thus affect the total production of electricity.

#### 5.1.1 Solar radiation on site

In the Adriatic coast region, the average annual radiation of the horizontal surface with solar radiation ranges from 1.60 MWh/m<sup>2</sup> for the outer islands, to about 1.3 MWh/m<sup>2</sup> in the northern part of the coast.

Data on solar radiation are available in various publications, databases and publicly available tools on the Internet. The data presented in this way are most often based on data obtained by measurement, satellite tracking or various estimation models. For the territory of the Republic of Croatia, data for 43 locations are contained in the Manual for Energy Use of Solar Radiation - Solar Radiation in the Republic of Croatia. Within this publication, both monthly and annual maps of solar radiation for the territory of the Republic of Croatia are given, and EIHP uses this publication as a basis in its estimates of solar energy energy potential, strongly supports the use of data from this publication

Data for the location of the planned power plant are not available, but climatological data for Croatia are available and suitable for this purpose, including data on average temperature and average daily exposure to solar radiation from the surrounding meteorological stations: Rovinj, Opatija and Parg. Using the interpolation method, it is possible to estimate the energy potential of solar radiation, ie daily radiation by months for a specific location, based on known data from the surrounding locations. The table below shows the meteorological stations for which the necessary data are available and suitable, their basic data, and weight factors needed to estimate the average daily irradiance by months.

Table 5-1 Basic data from the meteorological stations in the vicinity of the location and Koper

Location	Latitude			Longitude			Altitude [m]	Effective distance [km]	Weight share
	°	'	dec	°	'	dec			
<b>Rovinj</b>	45	3	45,05	13	39	13,65	8	218,46	<b>0,249</b>
<b>Opatija</b>	45	20	45,33	14	19	14,31	5	157,50	<b>0,480</b>
<b>Parg</b>	45	36	45,6	14	38	14,63	863	209,52	<b>0,271</b>
<b>Bertoki</b>	45	47	45,79	16	13	16,22	25		

According to the values of weight factors  $w_i$ , shown in the table, the greatest impact on the calculation is expected from the nearest meteorological stations.

The annual irradiance of the horizontal surface for the location of the planned power plant is 0.98 MWh/m<sup>2</sup>, and the average daily irradiation of the horizontal surface by months ranges from 0.84 kWh/m<sup>2</sup> (December) to 4.47 kWh/m<sup>2</sup> (July). Table 5-2 shows the average daily irradiances of the horizontal surface and the mean air temperatures by months.

Table 5-2 Average daily irradiances of the horizontal surface and the mean air temperatures by months

Month	Air temperature (°C)	Horizontal surface (slope 0°)			
		Total	Dispersed	Direct	Reflect
January	1.2	0.99	0.62	0.24	0.00
February	2.1	1.61	1.11	0.51	0.00
March	4.0	2.48	1.60	0.82	0.00
April	6.6	3.37	2.24	1.21	0.00
May	9.6	4.13	2.74	1.53	0.00
June	11.6	4.45	2.96	1.70	0.00
July	13.0	4.47	3.13	1.90	0.00
August	12.1	3.84	2.58	1.52	0.00
September	9.9	2.98	1.97	1.23	0.00
October	7.0	1.98	1.34	0.69	0.00
November	3.9	1.14	0.71	0.29	0.00
December	1.9	0.84	0.54	0.18	0.00
<b>Total [MWh/m<sup>2</sup>]</b>	<b>6.91</b>	<b>0.98</b>	<b>0.66</b>	<b>0.36</b>	<b>0.00</b>

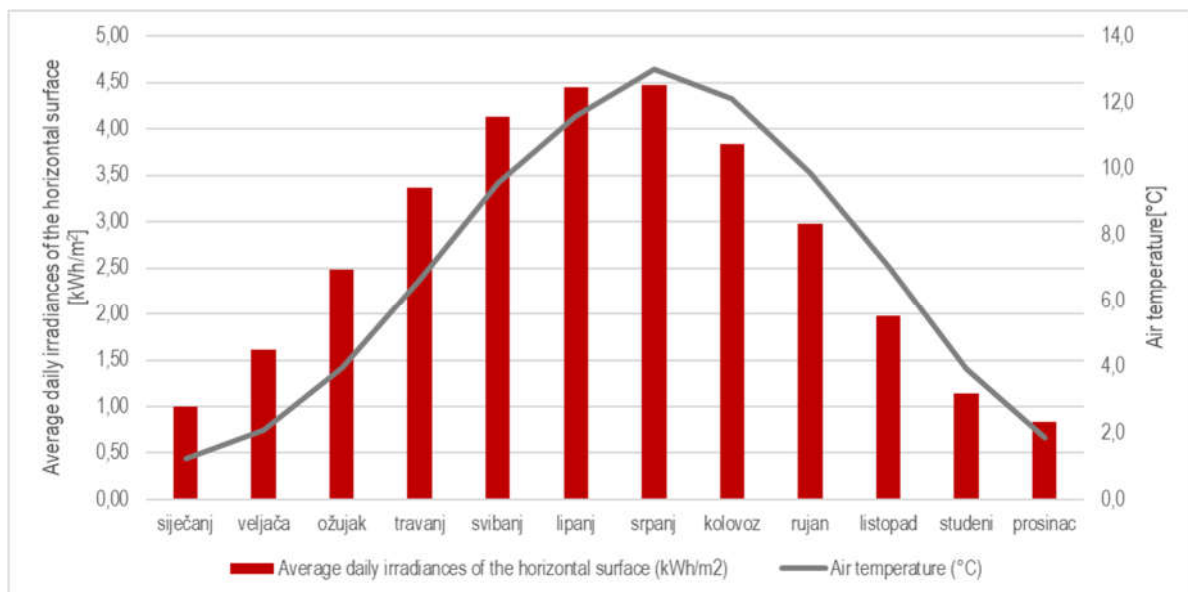

Figure 5-1 Average daily irradiances of the horizontal surface and the mean air temperatures by months

The irradiance of the inclined surface is an important piece of information for planning the use of solar energy systems. By placing the surface on a certain slope, it is possible to maximize the amount of irradiated energy during a certain period of the year. When installing integrated power plants, it is common to use the existing slope of the roof surfaces if the installation is performed on a sloping roof, or to use a fixed slope of the module of approximately 10-15 degrees offered by the manufacturer of the selected substructure.

Specifically for the observed case, the slope of the sloping roof is 5 degrees and the installation of photovoltaic modules is planned in parallel with the slope of the roof.

5.1.2 Location shading

The building is located on relatively flat terrain and there are no significant objects that would cause shading at the location. The shading diagram for the power plant location is shown in the following figure.

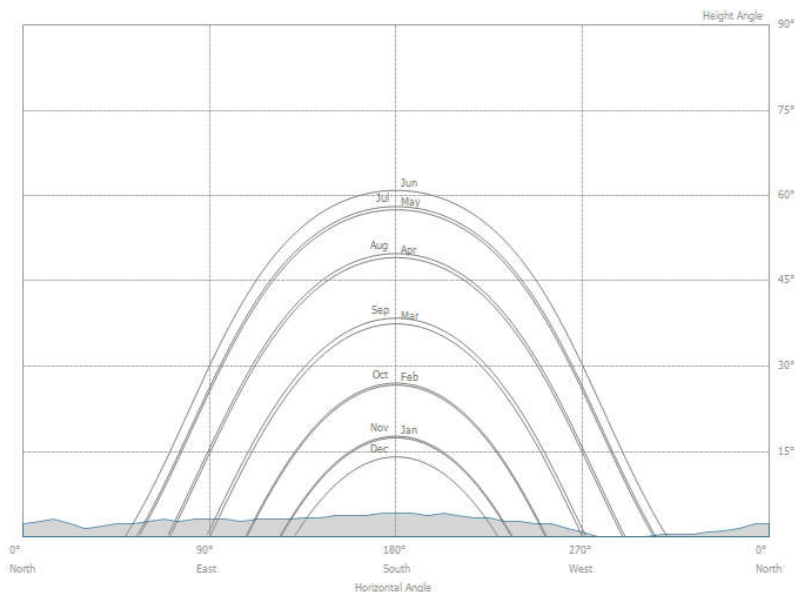

Figure 5-2 Shading on site, polar diagram display (Source: PVGIS)

5.2 Electricity production estimation

The calculation of electricity production was performed based on input data on solar radiation for the Koper location from Chapter Solar radiation on the location. The simulation of photovoltaic systems, according to the equipment and proposed solutions, was performed in a specialized simulation tool PV \* Sol 2022. In accordance with the conceptual design, the assumed inclination of the PV module is 23 °, with southeast orientation (azimuth 68 °), southwest orientation (azimuth 248 °) and south orientation (azimuth 158 °). The usual losses within photovoltaic systems and the limitation of the output power per inverter are also considered.

Table 5-3 Parameters for electricity production estimation

Parameter	Solar powerplant KS Bertoki
Source of solar radiation data	Solar radiation for Slovenia
Location	Koper (interpolation)
Solar radiation on horizontal plate	0.98 MWh/m <sup>2</sup>
Roof tilt	5°
Azimuth	Southeast (-40°); northwest (140°)
Mean air temperature	6.91 °C
Shading	Global shading as estimated
Method applied	PV*Sol 2022
PV module	Solvis SV72-330
Inverter	Huawei Sun2000-17KTL-M0, Sun2000-10KTL-M0
Expected losses	
Losses due to pollution / dirt	1.0 %
Power lines losses	Total losses in the power distribution lines of the power plant are assumed to be 2%

Table 5-4 shows the results of the work simulation / calculation of electricity production for SE Zadružni dom Bertoki, by months in kWh. The data refer to the electricity delivered from the photovoltaic power plant to the customer's distribution cabinet. The total expected annual electricity production is about 40526 kWh with a productivity of 944 kWh / kWp. for the considered technical solution.

Table 5-4 Electricity production results based on proposed technical solution

	kWh
<b>January</b>	1338.6
<b>February</b>	2034.4
<b>March</b>	3687.5
<b>April</b>	4304.5
<b>May</b>	5158.4
<b>June</b>	5231.1
<b>July</b>	5701.7
<b>August</b>	5046.7
<b>September</b>	3444.7
<b>October</b>	2246.8
<b>November</b>	1254.1
<b>December</b>	1077.5
<b>Total</b>	40526.00
<b>Productivity [kWh/kW<sub>p</sub>]</b>	944.66

### 5.3 Possibility analysis of electricity consumption at the location

The analysis of the possibilities of using energy on the site compares the profiles of electricity consumption and production. It should be noted that this analysis represents only one case, since the production is simulated from synthesized data according to average meteorological conditions, which do not refer to a specific year, while consumption data refer to a specific year, and to some extent depend on climatological parameters. However, the aim of this analysis is not to accurately determine the dependence of the production and consumption profiles, but to show the benefits of solar power plants.

The possibility of using energy at the location was analysed for a variant of the technical solution according to the supplier's data on electricity consumption of the facility for 2019. Electricity consumption data refers only to municipality consumption in the building. Other consumers data are not available. Power plant simulation is made with assumption to use all available roof surface and show maximum power plant production so that building owner can calculate possibility on creating energy community.

According to the supplier, the total electricity consumption of the observed facility was slightly more than 18940 kWh in 2019, and monthly consumption ranged between 947 kWh for November and 2674 kWh for January.

Load (consumption) data per hour were not available to the study developer. The user of the facility submitted monthly electricity bills for the observed facility, which is why it was not possible to overlap the hourly curves of the facility's consumption with the curves of solar power plant production for each day.

Figure 5-3 shows the monthly consumption profile of the observed object and PV production. The consumption profile partly corresponds to the solar power generation profile. The expected increase in daily consumption corresponds to part of the installed power of the power plant, and peak loads typically do not match the installed and connected power of the power plant, so surplus electricity production can be expected that cannot be used on site but distributed further

through the power system. In particular, on sunny weekends, an excess of electricity in relation to consumption can be expected.

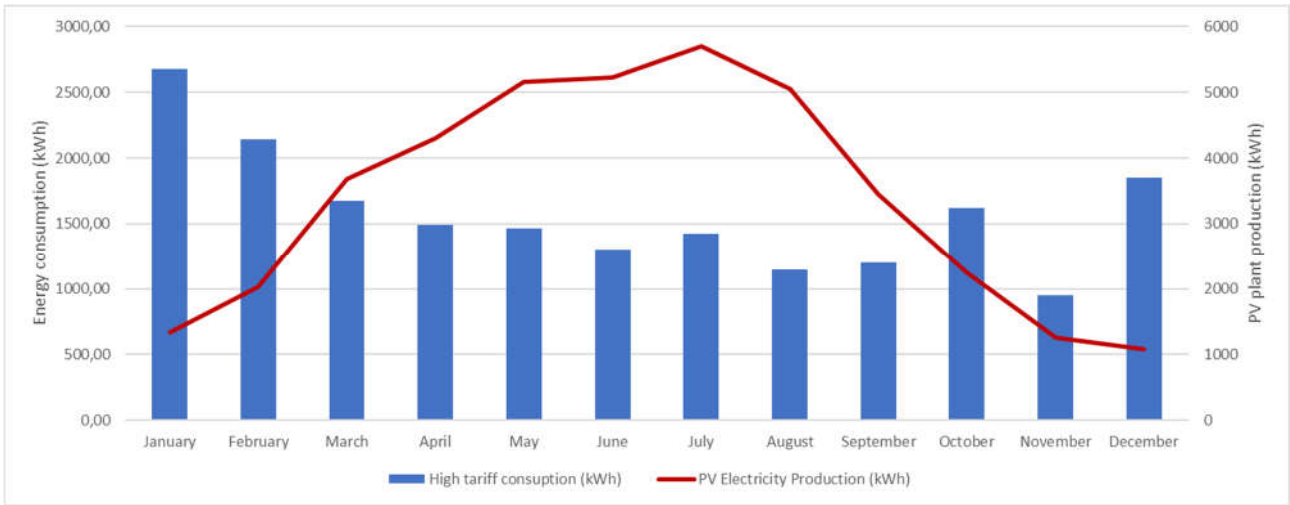

Figure 5-3 Monthly consumption in relation to PV production for KS Bertoki

The developer assumed a typical overlap of time coincidence of electricity needs of this type of facility with the curves of electricity production from photovoltaic power plants, which means that physically, some amount of energy will be delivered to the grid. However, due to the self-consumption model and legal framework, all energy will be balanced with consumption within object or within energy consumed in energy community.

Finally, on an annual basis, it is expected that, of the total production, about 7,502 kWh will be used directly in the observed facility. The rest of the production, ie about 33,024 kWh, will be handed over to the electricity network.

Figure 5-4 graphically shows the energy flows for the analysed case.

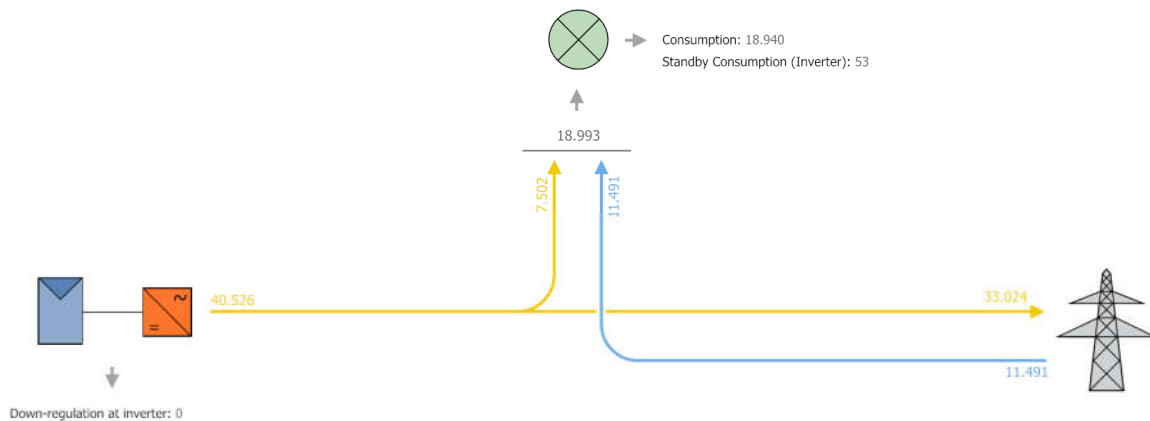

Figure 5-4 Energy flow graph (kWh)



# Economic and financial analysis of the project

## 6 Basic parameters

### 6.1 Estimation of Investment

Investment in small scale PV plant is mostly focused towards equipment, i.e. PV modules, inverters, cables, mounting structure and other parts of PV systems, but cost of grid connection, works, project documentation and other cost are also present for investment.

Table 6-1 shows estimated investment cost, by category. Figures are based on estimation of different component costs.

Table 6-1 Estimated investment costs, by category

Component	Specific cost [€/kW]	Investment [€]
<b>PV modules</b>	500	21,450.00
<b>Inverters</b>	120	4,440.00
<b>Other electrical equipment (cables, switches, enclosures...)</b>	60	2,574.00
<b>PV module holders</b>	55	2,035.00
<b>Other equipment</b>	25	1,072.50
<b>Total equipment:</b>		31,571.50
<b>Works</b>	90	3,861.00
<b>Grid connection</b>		1,500.00
<b>Project documentation</b>	50	2,145.00
<b>Unspecified and unexpected costs</b>	20	858.00
<b>Total [kn]:</b>		39,935.50
<b>Specific cost [€/kWp]</b>		930.90

**Note:** Above presented number are estimation of figures for investment, and are for orientational purposes only. Exact investment cost depends on offers from equipment providers.

## 6.2 Estimation of Operational costs

Operational costs are estimated based on previous experience on typical costs for PV system on similar objects. Typically, these costs are around 1 % of investments, and this number is estimated as operational cost for this case.

## 6.3 Model for estimation of self-consumed electricity in energy community

Net-metering system allows balance of produced energy with consumed energy over some period, typically one month, as there is not possible to perfectly match energy production from PV with electricity consumption in the object.

Slovenian legal framework allows, beside other, defines two possible models of self consumption:

- Self-consumption model, whereas electricity produced is balanced with consumption over the year, but only for one consumer;
- Energy community, whereas energy produced is balanced with other consumers within energy community, based on formal agreement of energy sharing.

For this analysis, it is presumed that all consumers within analyzed object will form a energy community. In that case, it is presumed that all produced energy will be consumed/balanced in object, based on the Energy community model. Also, for this model, it is estimated that all participants have same electricity price, as electricity price for other consumers is not available.

Analysed object is object with single tariff model of consumption, therefore only one tariff will apply for financial analysis.

## 7 Financial analysis

Based on previous assumptions, as well as input parameters on level of CAPEX, OPEX, PV production, electrical energy consumption of the object, tariff model and cost of associated energy financial analysis has been conducted.

Lifetime of PV power plant is estimated at 25 years, and all generated income and operating cost are estimated over this period.

The following indicators were calculated in the cost-effectiveness calculation:

- net present value (NPV), the value of the project in euros on the first day of the year in which the investment begins
- internal rate of return (IRR)
- pay back period (PBP).

The cost-effectiveness analysis does not evaluate the financial and accounting aspects of the project (such as financing costs, depreciation costs and tax liabilities) because they are subject to legal regulations and company policies. The aim of the cost-effectiveness budget is to determine whether the project achieves sufficient accumulation of funds to justify the invested funds.

The discount rate of 4% is estimated.

This project achieves a positive net present value (NPV) of 13,196 € and internal rate of return (IRR) of 1.57%. The payback period is 11 years. For the profitability index it is crucial for the project evaluation that is it greater or equal of 1, which is achieved in this project (2.15).

Size of the system is estimated based maximum available roof surface, as it is expected that energy community model will be used on this object.

Furthermore, above mentioned price for electricity is far bellow current energy prices, and is expected to increase in future, at least to the 0.2 €/kWh.

Table 7-1 Financial indicators of cost-effectiveness for the project

<b>Installed PV capacity [kW<sub>p</sub>]</b>	42.9
<b>PV plant grid connection capacity [kW]</b>	37
<b>Estimated investment cost</b>	39,935.50 €
<b>Estimated operational cost (annually)</b>	399.36 €
<b>PV productivity [kWh/kW<sub>p</sub>]</b>	944.66
<b>PV energy production [kWh]</b>	40,526.00
<b>Yearly electricity consumption [kWh]</b>	18,940.00
<b>Yearly cost for electricity without PV</b>	1,791.91 €
<b>Yearly cost for electricity with PV</b>	0.00 €
<b>Yearly payment for excess PV (energy community)</b>	2,042.25 €
<b>Discount rate</b>	4%
<b>IRR</b>	2%
<b>NPV</b>	13,195.55 €
<b>PbP [years]</b>	11
<b>Profitability index</b>	2.15

Several factors can affect the future operation of a power plant. Some of these are the market price of electricity, the amount of electricity produced and the amount of investment costs. Since the amount of energy produced is the result of the modelling described in the previous sections, it is assumed that this is not a variable factor, in economic sense. Also, profitability of the project depends on the cost of PV system, as this number is estimated based on the previous experience, but can differ based on the exact offers. The sensitivity analysis was therefore based on variability of investment, in range for 80% of estimated up to 120% of estimated, increase on electricity price, up to 0.3 €/kWh for high tariff. Payback period is the cost effectiveness indicator analysed under these scenarios.

Table 7-2 Sensitivity analysis – Variability of investment in PV system and increase of high tariff electricity supply

Payback period	Variability of investment in PV system									
	11	80%	85%	90%	95%	100%	105%	110%	115%	120%
High tariff electricity supply [€/kWh]	0.09	9	9	10	11	11	12	13	9	9
	0.1	8	9	10	10	11	11	12	8	9
	0.15	6	7	7	8	8	9	9	6	7
	0.2	5	5	6	6	6	7	7	5	5
	0.25	4	4	5	5	5	6	6	4	4
	0.3	4	4	4	4	4	5	5	5	4

Above presented figures shows that investment in this project is profitable and feasible, even with current electricity price, which are expected to increase in future.

## 8 Conclusion

Financial calculations show very perspective financial indicators, with payback period of 11 years and positive net present values in any given scenario. However, due to the fact that intention of this project is selfconsumption of produced electrical energy as part of energy community, PV system with maximum capacity of 37 kW was proposed. For this case, profitability index, with current energy prices, is around 2.13, meaning investment will return for more than two times during lifetime.

Current sharp electricity price rise on market are expected to increase also electricity prices for final consumers. Although increase of prices will increase final energy bill, this increase influence shorter payback period and better financial indicators.



## Accelerating solar energy deployment in coastal municipalities

Document: **D.III.1\_A – Feasibility study for “Ktajevska skupnost Bertoki”, Koper**  
Authors: Andro Bačan & Srećko Tamburović (Energy Institute Hrvoje Požar)  
Date: May 2022

Project partners:



Univerza v Ljubljani



Project Solar Adria is supported by:

Supported by:



on the basis of a decision  
by the German Bundestag